

版本 Rev.	日期 Date	变更文件号 ECN NO.	变更内容 Revisions	设计 By

Dimension: (Unit: mm)

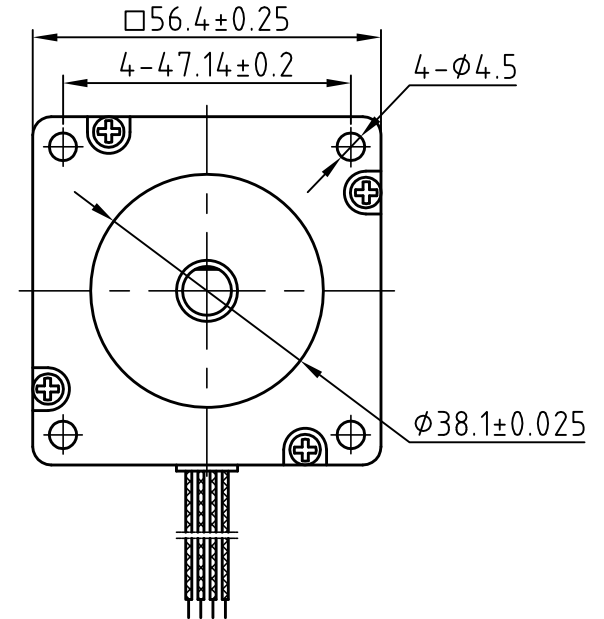
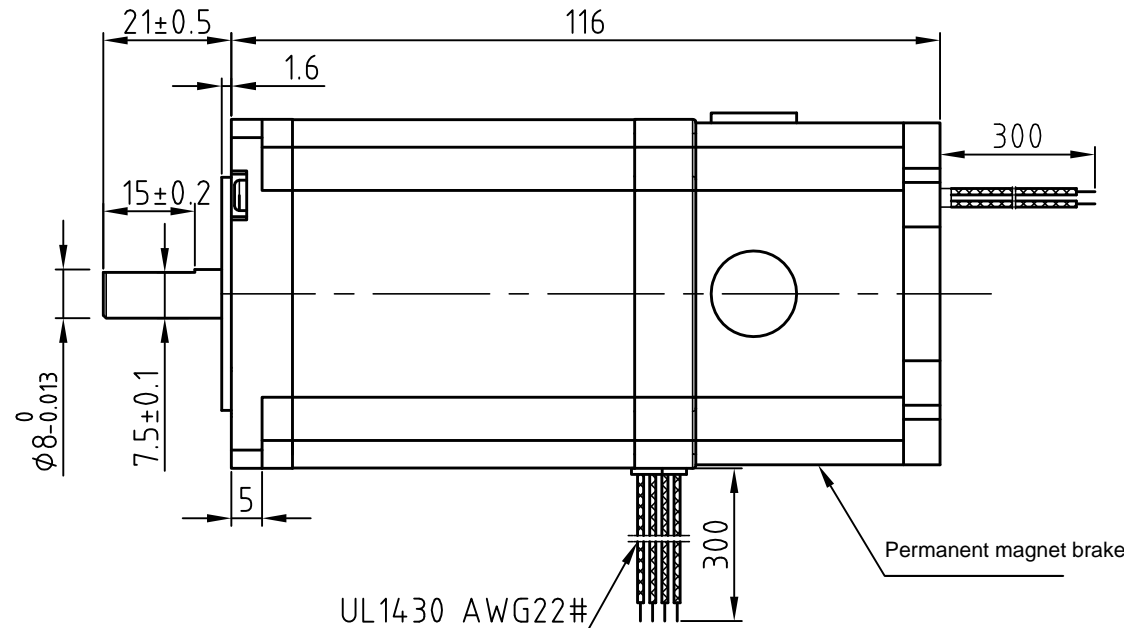

Motor Specification

Step angle	1.8°
Position accuracy	1.8±0.09°
Dielectric strength	500VAC 1min
Insulation resistance	100MΩ(500VDC)
Insulation class	B
Temp rise(Max)	80K
Radial play	Max.0.02mm(Load 450g)
Axial play	Max.0.08mm(Load 900g)
Current/phase	5.0 A
Voltage	2.2 V
DC Resistance/phase ±10%	0.44 Ω
Inductance/phase ±20%	1.8 mH
Holding torque	2.1 N·M
Inertia	0.48 kg·cm ²
Weight	1.3 kg

Brake Specification:

Static friction torque	0.75 N·M
Voltage	24 V
Wattage	6.6 W
Armature pull in time	0.03 S
Armature release time	0.01 S
Rotating Inertia	0.019 kg·cm ²
Weight	0.3 kg
Heat resistance class	F

Motor Connctions:

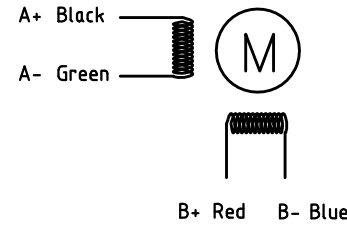

Brake Connctions:

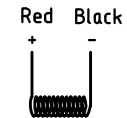

设计 Designed	日期 Date	材料 Material	深圳市雷赛智能控制股份有限公司 SHENZHEN LEADSHINE TECHNOLOGY CO., LTD.
审核 Checked		第一角画法 First Angle projection	名称 Title Stepper Motor with Brake
批准 Approved		重量 Weight	57HSB21A
料号 Part No.		比例 Scale	图号 DWG. NO.
		阶段标记 Stage Mark	
		共 1 页 第 1 页 Sheet 1 of 1	