

Dimension: (Unit: mm)

版本 Rev.	日期 Date	变更文件号 ECN NO.	变更内容 Revisions	设计 By
V1.0	17.5.24		60机座、2.2NM	王洪松
	17.09.22			Max

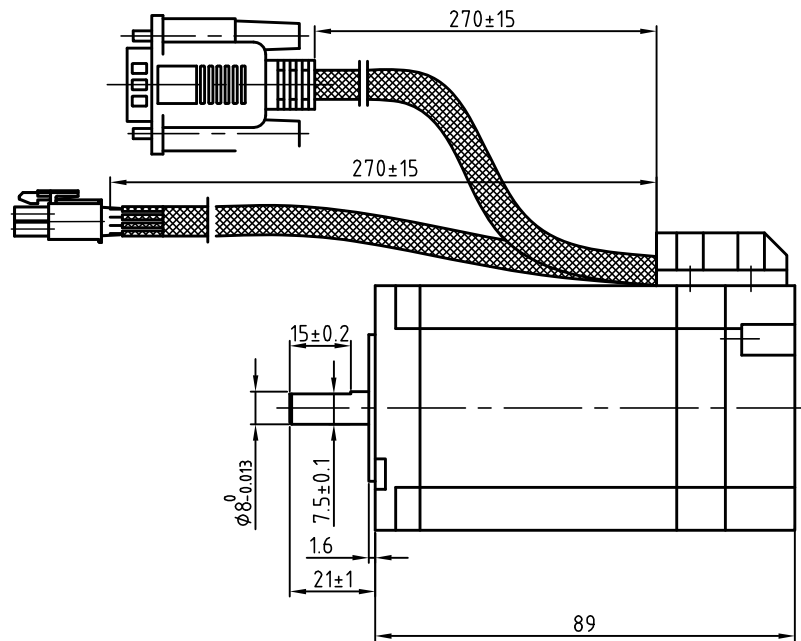

Motor Connctions:

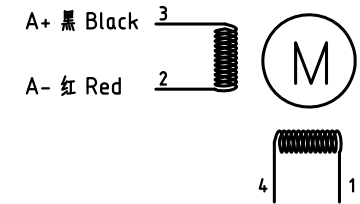
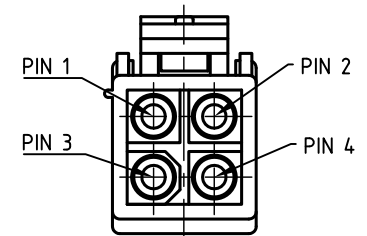

B+ 黄 Yellow B- 绿 Green

Encoder Signals

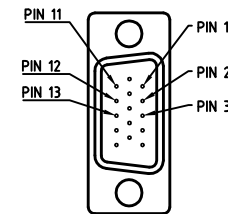

PIN	1	2	3	11	12	13
Color	BLK	RED	WHT	YEL	GRN	BLU
Define	A+	VCC	GND	B+	B-	A-

Common Rating

Step angle	1.8°
Position accuracy	1.8±0.09°
Dielectric strength	500VAC 1min
Insulation resistance	100MΩ(500VDC)
Insulation class	B
Temp rise(Max)	80K
Radial play	Max.0.02mm(Load 450g)
Axial play	Max.0.08mm(Load 900g)

Specification

Current/phase	5.0 A
Voltage	1.7 V
DC Resistance/phase ±10%	0.33 Ω
Inductance/phase ±20%	1.05 mH
Holding torque	2.2 N·M
Inertia	0.49 kg·cm <sup>2</sup>
Weight	1.2 kg
Encoder resolution	1000 cpr

设计 Designed	王洪松	日期 Date	17.5.24	材料 Material	深圳市雷赛智能控制股份有限公司 SHENZHEN LEADSHINE TECHNOLOGY CO., LTD.
审核 Checked	刘佩峰	17.5.24		第一角画法 First Angle projection	名称 Title
批准 Approved	田天胜	17.5.24		重量Weight 比例Scale 阶段标记 Stage Mark	CS-M22422
料号 Part No.				共 1 张 第 1 张 Sheet 1 of 1	图号 DWG. NO.