

iES-2320

Integrated Easy Servo

Motor + Drive + Encoder, 20-50VDC, NEMA23, 2.0Nm



Features

- | Easy servo control technology to combine advantages of open-loop stepper systems and brushless servo systems
- | Closed-loop controls to eliminate lose of steps, stall or movement synchronization
- | Integrated compact size for saving mounting space & setup time, and reducing electrical interference
- | 1000-line integrated optical incremental encoder for accurate position control
- | High starting torque and quick response
- | Smooth motor movement with no vibration
- | Excellent respond time, quick acceleration, and very high high-speed torque (30% over open-loop)
- | Load-dependent dynamic current output from drive to motor to significantly motor heating deduction
- | Input voltage from 20 to 50 VDC; 6.0A peak current output from drive to motor
- | 2 Nm (285 oz-in) holding torque stepper motor with NEMA 23 frame size installation
- | 16 micro step resolution options via DIP switches; or any value from 200-51,200 (increased by 1) via software configuration
- | Isolated control inputs of Pulse, Direction and Enable
- | No tuning for plug and play setup
- | In-position and fault outputs to external motion controllers for complete system controls.
- | Over voltage, over-current, and position-error protection

Descriptions

Leadshine's iES-2320 integrated easy servo motor is a NEMA 23 stepper motor integrated with a 1,000-line (4,000 PPR) encoder and an easy servo drive. At very compact size and with all components integrated, the iES-2320 can save mounting space, eliminate encoder connection & motor wiring time, reduce interference, and cut/reduce cable and labor costs.

By adopting Leadshine's latest easy servo control technology, the easy servo drive of the iES-2320 can drive the stepper motor with high starting torque, high precision, smooth movement, and extra low noise at low speed movement with no obvious resonance area. Different from constant-output-current output from a drive to a stepper motor in normal open-loop stepper controls, output current of the iES-2320 is dynamic and changes depending on load condition, same as servo controls. Therefore, it can significantly reduce motor heating and increase motor lifetime. The drive takes step & direction input commands, and is capable of outputting in-position and fault signals back to a motion controller or external devices, for complete system controls.

Descriptions (Continued)

The integrated 1,000-line encoder of the iES-2320 offers the real-time motor shaft position to the drive. Based on that position, the drive can then close the loop between the motor and drive, ensure no step is lost, and eliminate the possibility of stall or loss of movement synchronization which is often found in open-loop stepper systems. By getting rid of torque reservation in open-loop stepper systems, the iES-2320 can significantly improve high speed performance by as much as 30%. In addition, the iES-2320 performs much better in response time and speed acceleration over open-loop step systems.

Compared with brushless servo systems, the iES-2320 has much higher low speed torque, no overshooting & zero settling time, no overshooting, no hunting, and no/little tuning. Significant cost cutting also makes the iES-2320 ideal for the motion control systems in many applications.

Applications

Leadshine's iES-2320 integrated easy servo motor offers an alternative solution to fill the gap between budget open-loop stepper systems, and expensive high performance brushless servo systems. It combines the features of high low-speed torque of open-loop stepper, and closed-loop movements of traditional servo systems. Integration design with motor, drive, and encoder significantly reduces setup time and cut costs of your control systems.

Advanced features over open-loop stepper systems, such as much higher high-speed torque, no loss of movement synchronization, much lower motor heating, no obvious resonance area, etc., make the iES-2320 ideal for upgrading stepper systems to get performance boost for many stepper applications such as CNC routers, CNC laser cutting machines, CNC milling machines, CNC lathes, medical / biotech equipments, lab automation instruments, etc.

Features over traditional brushless servo systems, such as significant lower costs, no hunting, no overshooting, easy setup, etc., make the iES-2320 ideal products in many traditional servo applications such as short distance movement boding type machines and vision applications. Its natural feature of high low-speed torque makes the iES-2320 a perfect product for replacing many high-cost servo applications with gear head speed reduction.

Specifications

Electrical Specifications

Parameter	Min	Typical	Max	Unit
Input Voltage	20	36	50	VDC
Output Current	0	-	6.0(Peak)	A
Pulse Input Frequency	0	200	500	kHz
Pulse Voltage	0	5	24	V
Logic Signal Current	7	10	16	mA
Isolation Resistance	100	-	-	MΩ

Operating Environment

Cooling	Natural Cooling or Forced cooling	
Operating Environment	Environment	Avoid dust, oil fog and corrosive gases
	Ambient Temperature	0°C — 40°C (32°F — 104°F)
	Humidity	40%RH — 90%RH
	Operating Temperature (Heat Sink)	70°C (158°F) Max
Storage Temperature	-20°C — 65°C (-4°F — 149°F)	

Motor Specifications

Part Number	Holding Torque	Motor Length (L)	Motor Inductance	Weight
iES-2320	2.0 Nm	80+/-1mm	1.63mH	1280 g

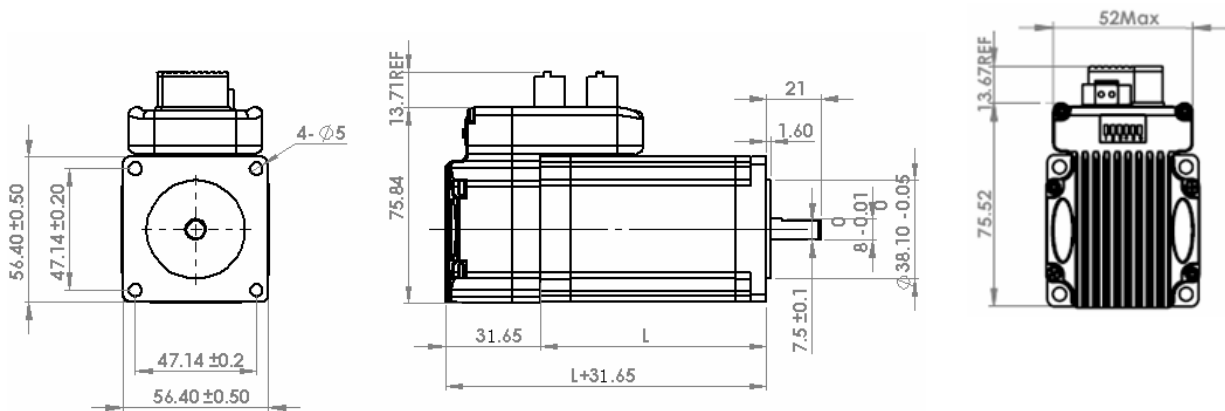

Mechanical Specifications

L = 80+/-1mm, total length = 112+/-1mm



Protection Indications

The green light turns on when iES-2320 is powered on and functions normally. In any case that drive protection is activated, the red LED blinks periodically (in every 4 seconds) to indicate the error type. In each blink, red light is on for 0.2 second and then off for 0.3 second.

Priority	Time(s) of Blink	Sequence wave of red LED	Description
1st	1		Over-current protection activated when peak current is greater than 18A
2nd	2		Over-voltage protection activated when drive working voltage is greater than 60VDC
3rd	7		Position following error activated when position following error limit exceeded the pre-set value (1000 pulses by default, or value set value by a customer)

Connectors and Pin Assignment

Leadshine iES-2320 has three connectors, a connector for control signals connections, a connector for RS232 communication connection, and a connector for power connections.

Control Signal Connector			
Pin	Name	I/O	Description
1	PUL+	I	<u>Pulse signal:</u> In single pulse (pulse/direction) mode, this input represents pulse signal, active at each rising or falling edge (Set by DIP switch S6). In double pulse mode (software configurable), this input represents clockwise (CW) pulse, active both at each high level and low level. 4.5-24V for PUL-HIGH, 0-0.5V for PUL-LOW. For reliable response, pulse width should be longer than 2.5 μ s for 200K MAX input frequency or 1 μ s for 500K MAX input frequency.
2	PUL-	I	
3	DIR+	I	<u>Direction Signal:</u> In single-pulse mode, this signal has low/high voltage levels, representing two directions of motor rotation. In double-pulse mode (software configurable), this signal is counter-clock (CCW) pulse, active both at high level and low level. For reliable motion response, DIR signal should be ahead of PUL signal by 5 μ s at least. 4.5-24V for DIR-HIGH, 0-0.5V for DIR-LOW. Toggle DIP switch SW5 to reverse motion direction.
4	DIR-	I	
5	ENA+	I	<u>Enable signal:</u> This signal is used for enabling/disabling the driver. By default, high level (NPN control signal) for enabling the driver and low level for disabling the driver. It is usually left UNCONNECTED (ENABLED). Please note that the PNP and Differential control signals are on the contrary, namely Low level for enabling. The active level of ENA signal is software configurable.
6	ENA-	I	

Connectors and Pin Assignment (Continued)

Control Signal Connector			
Pin	Name	I/O	Description
7	PED+	O	<u>In-position Signal</u> : OC output signal, activated when actual motor position reaches to target position. This port can sink or source MAX 20mA current at 24V. By default, the impedance between PED+ and PED- is high in normal operation and changed to low when the target position is reached. The active impedance of in-position signal can be software configurable (See software manual).
8	PED-	O	
9	ALM+	O	<u>Alarm Signal</u> : OC output signal, activated when one of the following protection is activated: over-voltage, over current and position following error. They can sink or source MAX 20mA current at 24V. By default, the impedance between ALM+ and ALM- is low at normal operation and becomes high when any protection is activated. The active impedance of alarm signal is software configurable.
10	ALM-	O	

Power Connector			
Pin	Name	I/O	Description
1	+Vdc	I	Power Supply Input (Positive) 20-45VDC recommended. Please leave reasonable reservation for voltage fluctuation and back-EMF during deceleration.
2	GND	GND	Power Ground (Negative)

RS232 Communication Connector			
Pin	Name	I/O	Description
1	+5V	O	+5V power output (Note: Do not connect it to PC's serial port)
2	TxD	O	RS232 transmit.
3	GND	GND	Ground.
4	RxD	I	RS232 receive.
5	NC	-	Not connected.

DIP Switch Settings

Micro Step Resolution (S1-S4)

Micro step resolution of the iES-2320 can be configured via a 4-bit DIP switch, or Leadshine's tuning software ProTuner. When all bits of the DIP switch are at "ON" positions, the integrated easy servo drive will take the micro step resolution setting set by the software (4000 by default). In this case, a user can re-configure the resolution to any value between 200 and 51, 200 (increased by 1) through software. If any bit of the DIP switch is at "OFF" position, the integrated drive will take micro step revolution setting determined by bit positions of the DIP switch. Use the following table for their resolution settings via the DIP switch.

DIP Switch Settings (Continued)

Micro Step Resolution (S1-S4)

Steps/Revolution	S1	S2	S3	S4
Software Configured(Default 4000)	On	On	On	On
800	Off	On	On	On
1600	On	Off	On	On
3200	Off	Off	On	On
6400	On	On	Off	On
12800	Off	On	Off	On
25600	On	Off	Off	On
51200	Off	Off	Off	On
1000	On	On	On	Off
2000	Off	On	On	Off
4000	On	Off	On	Off
5000	Off	Off	On	Off
8000	On	On	Off	Off
10000	Off	On	Off	Off
20000	On	Off	Off	Off
40000	Off	Off	Off	Off

Motor Shaft Direction (S5)

DIP switch S5 is used for changing motor shaft rotation direction. Changing position from “ON” to “OFF”, or “OFF” to “ON” will reverse iES-2320 rotation direction.

Active edge of input pulse (S6)

DIP switch S6 is used for setting the active edge of a pulse signal. The motor shaft moves one micro step for each active pulse edge. Use the following table for your reference

S6	On	Off
	Active rising edge of input pulse	Active falling edge of input pulse

Current Control Detail

Leadshine’s iES-2320 integrated step servo motor is integrated with a high-resolution 1,000-line optical incremental encoder. That encoder can send the real-time shaft position back to the integrated drive of the iES-2320. Like traditional servo controls, the drive can automatically adjust the output current to the motor. The output current ranges between the holding current and the close-loop current. When there is no pulse sent to the drive, the iES-2320 goes into idle mode and the actual motor current is determined by the holding current percentage (similar to “idle current” of open loop stepper drives). In normal working mode, iES-2320 monitors the actual shaft position all the time. The current outputted to the motor changes dynamically based on the tracking error between the actual position and the commanded position.

Current Control Detail (Continued)

By default, holding current percentage of the iES-2320 is 40% of the peak current and the close-loop current percentage is 70%, unless you change them from Leadshine's configuration software (see software manual). Actual current outputted to the motor can be calculated as follows:

$$\text{Holding Current} = 6A \times \text{Holding Current Percentage (\%)}$$

$$\text{MAX Close loop Current} = 6A \times \text{Close Loop Current Percentage (\%)}$$

Low holding current can reduce motor heating however also reduces the holding torque which is used to lock the motor shaft at standstill. It is recommended to determine the holding current by whether or not there is big vibration at start-up and how much lock torque is required, based on your actual applications.

Fine Tuning

Leadshine already loads default current-loop parameters and position-loop parameters. Those default parameter values have been optimized. They should be good enough for most industrial applications, and there is no need to tune them. However, if you want to fine tune the iES-2320 for best performance for your applications, Leadshine also offers tuning software, ProTuner, which allows you to adjust those current-loop and position-loop parameters (see software manual).

Typical Connections

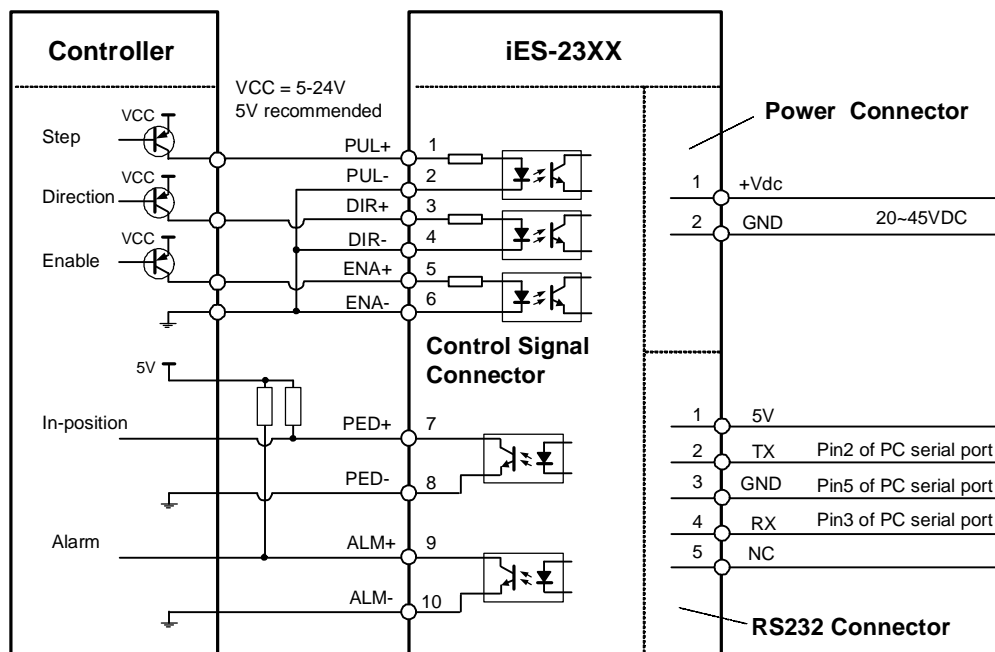

Connect iES-23XX to controller of sinking output

Typical Connections (Continued)

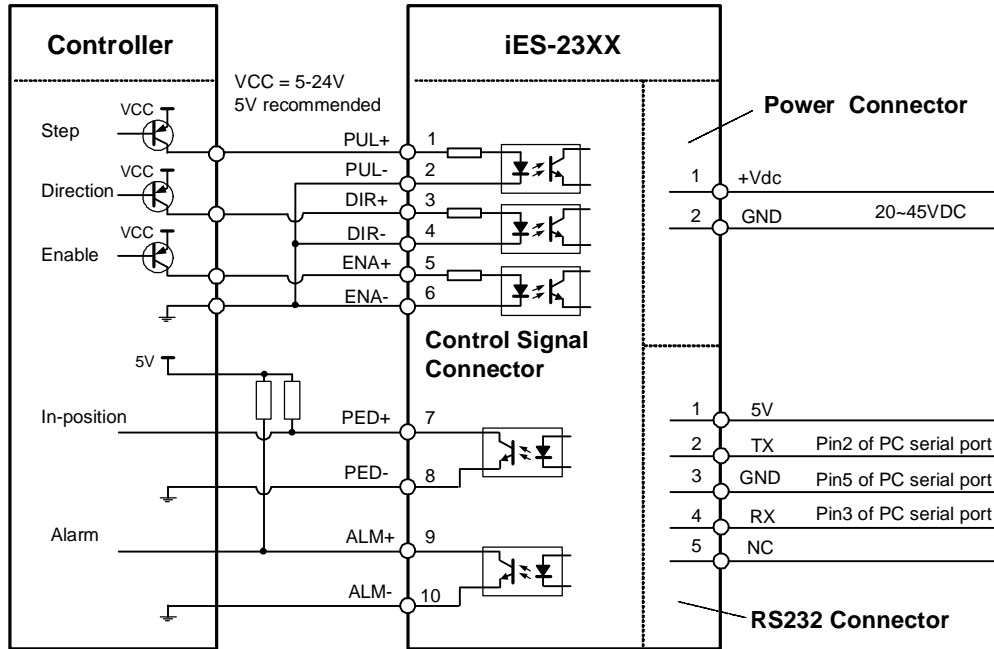

Connect iES-23XX to controller of sourcing output

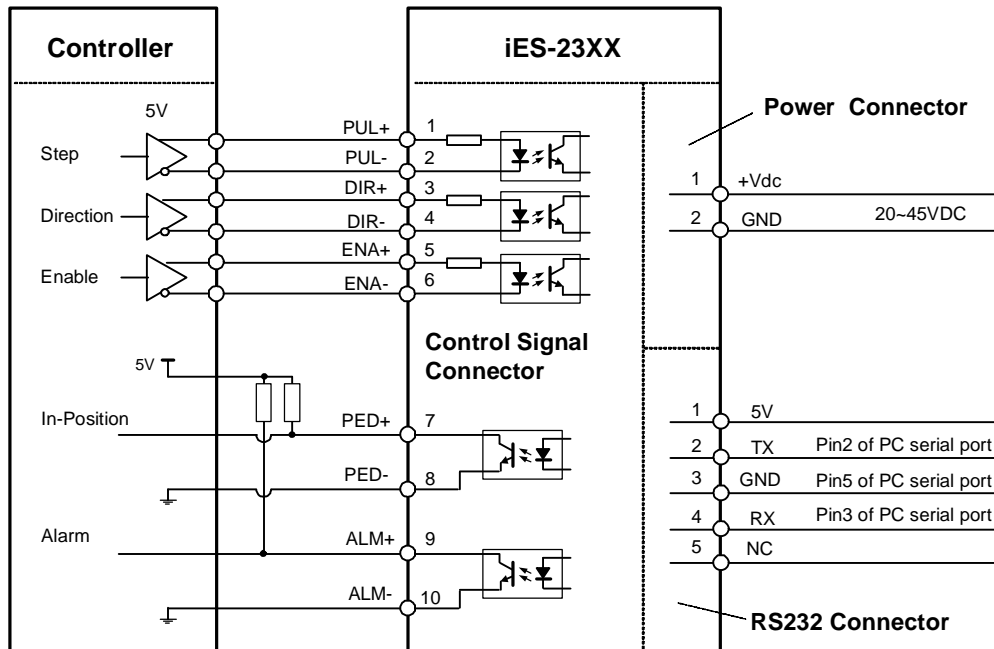

Connect iES-23XX to controller of differential output

RS232 Communication Cable Connections

Note1: The RS232 communication port is not isolated. Please use an isolated power supply for the iES-23xx when the PC's serial port is not isolated.

Note2: Do not plug or unplug the connector when power is on.

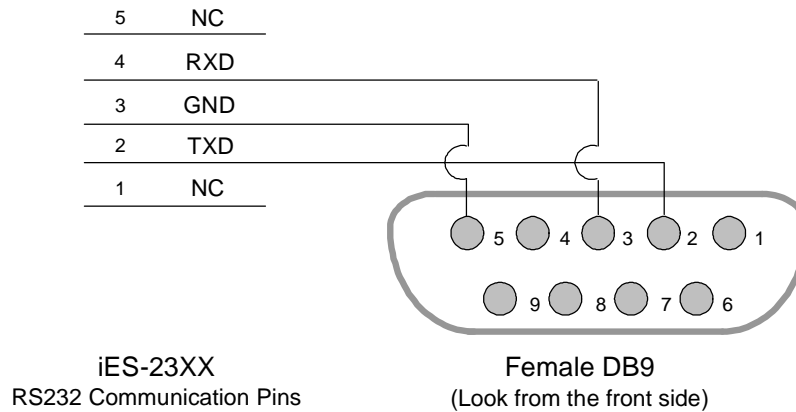

Speed-Torque Curve

Note: The following curves are based on 20% holding torque percentage and 70% close-loop current percentage of the iES-2320. If higher torque at high speed is required, you can change the holding torque percentage and close-loop current percentage to 100%. See software manual.

