

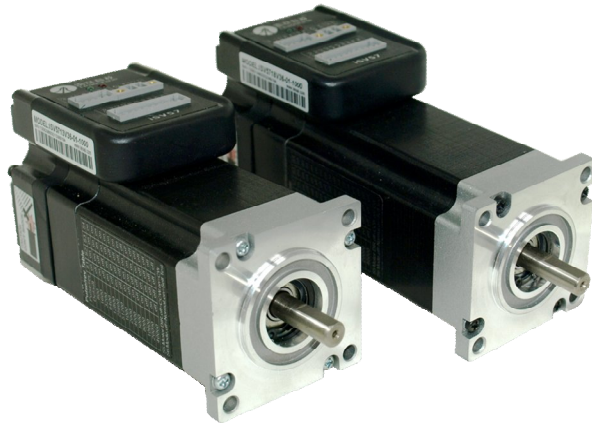

# Leadshine

## Integrated Servo Motor *Datasheet*

### *iSV-B23xxx*



BLDC Servo Motor + Drive, 24-36VDC, NEMA23, 90W-180W

Version 1.0.0

<http://www.Leadshine.com>

## Features

- I Integrated compact size for saving mounting space & setup time, and reducing electrical interference
- I Step & direction or CW/CCW command input for position or velocity control
- I Compatible mounting size with stepper motor
- I Smooth motor movement and good respond time
- I 15 micro step resolution options via DIP switches; or any value from 200-51,200 (Increased by 1) via software configuration
- I Isolated control inputs of Pulse, Direction and Enable
- I In-position and fault outputs to external motion controllers for complete system controls.
- I Over voltage, over-current, and position-error protection

## Descriptions

Leadshine's iSV-B23xxx integrated servo motor is a NEMA 23 brushless motor integrated with a 1,000-line (4,000 PPR) encoder and a servo drive. At very compact size and with all components integrated, the iSV-B23xxx can save mounting space, eliminate encoder connection & motor wiring time, reduce interference, and cut/reduce cable and labor costs.

## Applications

Leadshine's iSV-B23xxx can be used in various applications such as laser cutters, laser markers, high precision X-Y tables, labeling machines, CNC router, etc. Its unique features make the iSV-B23xxx an ideal choice for applications that require both low-speed smoothness and small mounting space.

## Specifications

### Electrical Specifications

Parameter	Min	Typical	Max	Unit
Input Voltage	20	36	50	VDC
Continuous Current	0	-	6.0(Peak)	A
Pulse Input Frequency	0	-	200 / 500 <sup>Note1</sup>	kHz
Pulse Voltage	0	5	24	V
Logic Signal Current	7	10	16	mA
Isolation Resistance	100	-	-	MΩ

Note 1: The max pulse frequency is software configurable

### Motor Specifications

Part Number	iSV-B23090 / iSV-B23090 -01	iSV-B23130 / iSV-B23130-01	iSV-B23180 / iSV-B23180-01	Unit
Rated Power	90	130	180	W
Rated Torque	0.30	0.45	0.6	N.M
Peak Torque	0.90	1.1	1.5	N.M
Rated Speed	3000	3000	3000	RPM
Peak Speed	4000	4000	4000	RPM
Rated Voltage	36	36	36	VDC
Weight	0.95	1.25	1.54	Kg

### Operating Environment

Cooling	Natural Cooling or Forced cooling	
Operating Environment	Environment	Avoid dust, oil fog and corrosive gases
	Ambient Temperature	0°C — 40°C (32°F — 104°F)
	Humidity	40%RH — 90%RH
	Operating Temperature (Heat Sink)	70°C (158°F) Max
Storage Temperature	-20°C — 65°C (-4°F — 149°F)	

### Mechanical Specifications

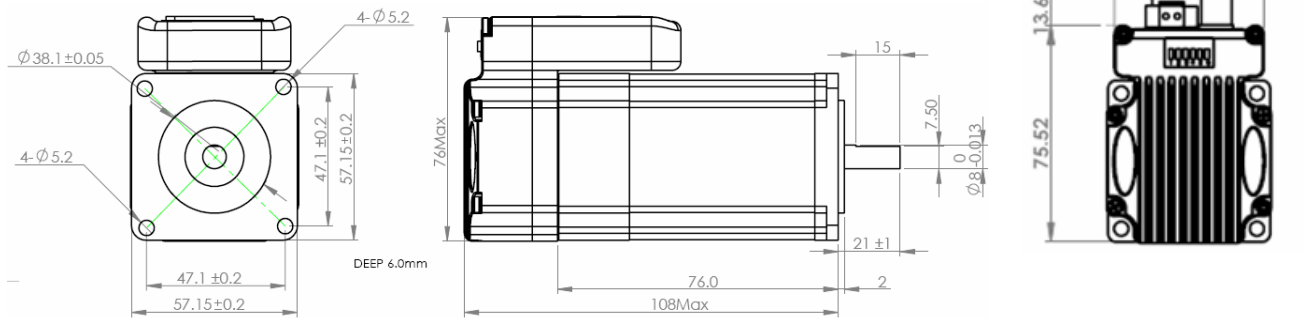

Mechanical Specification of iSV-B23090

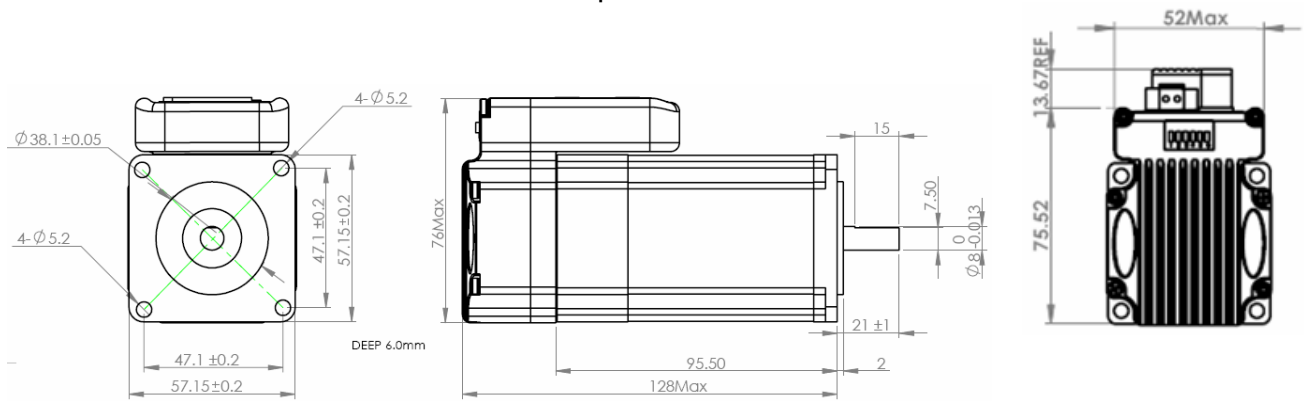

Mechanical Specification of iSV-B23130

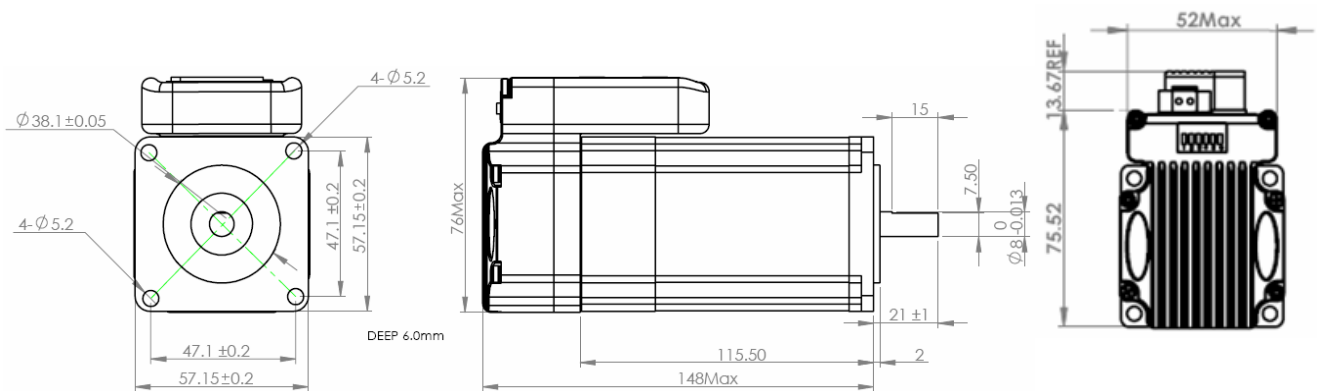

Mechanical Specification of iSV-B23180

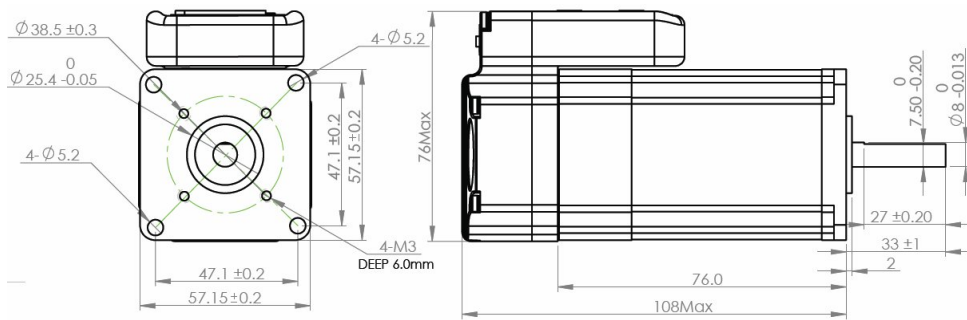
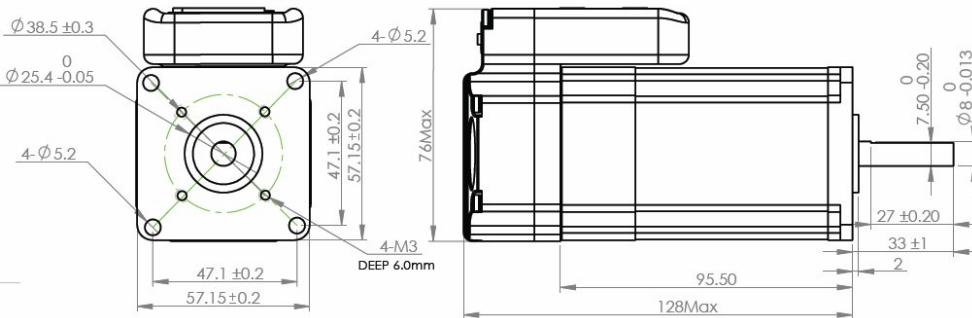
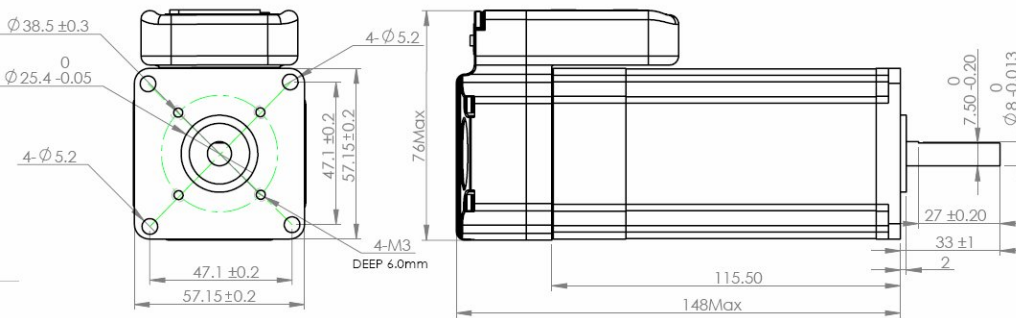
**Mechanical Specifications (Continued)**

**Mechanical Specification of iSV-B23090-01**

**Mechanical Specification of iSV-B23130-01**

**Mechanical Specification of iSV-B23180-01**

## Connectors and Pin Assignment

Leadshine iSV-B23xxx has three connectors, a connector for control signals connections, a connector for RS232 communication connection, and a connector for power connections.

Control Signal Connector			
Pin	Name	I/O	Description
1	PUL+	I	<u>Pulse Signal</u> : In single pulse (pulse/direction) mode, this input represents pulse signal, active at each rising or falling edge (Software configurable). In double pulse mode (software configurable), this input represents clockwise (CW) pulse, active both at each high level and low level. 4.5-24V for PUL-HIGH, 0-0.5V for PUL-LOW. For reliable response, pulse width should be longer than 2.5 $\mu$ s for 200K MAX input frequency or 1 $\mu$ s for 500K MAX input frequency.
2	PUL-	I	
3	DIR+	I	<u>Direction Signal</u> : In single-pulse mode, this signal has low/high voltage levels, representing two directions of motor rotation. In double-pulse mode (software configurable), this signal is counter-clock (CCW) pulse, active both at high level and low level. For reliable motion response, DIR signal should be ahead of PUL signal by 5 $\mu$ s at least. 4.5-24V for DIR-HIGH, 0-0.5V for DIR-LOW. Toggle DIP switch SW5 to reverse motion direction.
4	DIR-	I	
5	ENA+	I	<u>Enable signal</u> : This signal is used for enabling/disabling the driver. By default, high level (NPN control signal) for enabling the driver and low level for disabling the driver. It is usually left UNCONNECTED (ENABLED). Please note that the PNP and Differential control signals are on the contrary, namely Low level for enabling. The active level of ENA signal is software configurable.
6	ENA-	I	
7	PED+	O	<u>In-position Signal</u> : OC output signal, activated when actual motor position reaches to target position. This port can sink or source MAX 50mA current at 24V. By default, the impedance between PED+ and PED- is low for normal operation and becomes high when the target position is reached. The active impedance of in-position signal is software configurable.
8	PED-	O	
9	ALM+	O	<u>Alarm Signal</u> : OC output signal, activated when one of the following protection is activated: over-voltage and over current error. They can sink or source MAX 50mA current at 24V. By default, the impedance between ALM+ and ALM- is low for normal operation and becomes high when any protection is activated. The active impedance of alarm signal is software configurable.
10	ALM-	O	





## Connectors and Pin Assignment (Continued)

Power Connector			
Pin	Name	I/O	Description
1	+Vdc	I	Power Supply Input (Positive) 24-36VDC recommended. Please leave reasonable reservation for voltage fluctuation and back-EMF during deceleration.
2	GND	GND	Power Ground (Negative)

RS232 Communication Connector			
Pin	Name	I/O	Description
1	+5V	O	+5V power output ( Note: Do not connect it to PC's serial port)
2	TxD	O	RS232 transmit.
3	GND	GND	Ground.
4	RxD	I	RS232 receive.
5	NC	-	Not connected.

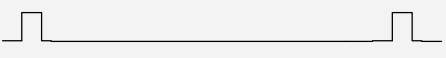
## Protection Indications

The green light turns on when iSV-B23xxx is powered on and functions normally. In any case that drive protection is activated, the red LED blinks periodically (in every 4 seconds) to indicate the error type. In each blink, red light is on for 0.2 second and then off for 0.3 second.

Priority	Time(s) of Blink	Sequence wave of red LED	Description
1st	1		Over-current protection activated when peak current is greater than 18A
2nd	2		Over-voltage protection activated when drive working voltage is greater than 60VDC
3rd	5		Encoder error activated when encoder connection or feedback is not correct
4th	7		Position following error activated when position following error limit exceeded the pre-set value (4000 pulses by default, or value set value by a customer)

## DIP Switch Settings

### Pulses/Rev Setting (S1-S4)

Pulses/Rev of the iSV-B23xxx can be configured via a 4-bit DIP switch, or Leadshine's tuning software ProTuner. When all bits of the DIP switch are at "ON" positions, the integrated servo drive will take the *pulses/rev setting* set by the software (4000 by default). In this case, a user can re-configure the *pulses/rev setting* to any value between 200 and 51,200 (increased by 1) through software. If any bit of the DIP switch is at "OFF" position, the integrated drive will take *pulses/rev setting* determined by bit positions of the DIP switch. Use the following table for their *pulses/rev setting* via the DIP switch.

#### Pulses/Rev (S1-S4)

Pulses/Rev	S1	S2	S3	S4
Software Configured (Default 400)	On	On	On	On
800	Off	On	On	On
1600	On	Off	On	On
3200	Off	Off	On	On
6400	On	On	Off	On
12800	Off	On	Off	On
25600	On	Off	Off	On
51200	Off	Off	Off	On
1000	On	On	On	Off
2000	Off	On	On	Off
4000	On	Off	On	Off
5000	Off	Off	On	Off
8000	On	On	Off	Off
10000	Off	On	Off	Off
20000	On	Off	Off	Off
40000	Off	Off	Off	Off

### Motor Shaft Direction (S5)

DIP switch S5 is used for changing motor shaft rotation direction. Changing position from "ON" to "OFF", or "OFF" to "ON" will reverse iSV-B23xxx rotation direction.

### Self-Test (S6)

By default, DIP switch S6 is OFF (normal mode) and the iSV-B23xxx responds to any pulse input. If it is turned ON, the iSV-B23xxx goes into self-test mode. In self-test mode, the motor shaft rotates 1 revolutions CW and then 1 revolutions CCW. The self-motion repeats until S6 is turned OFF (the motor shaft will stop immediately). Note that you are unable to communicate with the iSV-B23xxx via the RS232 port when it is in self-test mode.



## Fine Tuning

Leadshine already loads default current-loop parameters and position-loop parameters. The default parameter values of the current loop have been optimized and there is no need to tune them. However, you need to tune the position loop parameters for your application to achieve the best performance. The actual value is determined by power supply voltage, load inertia and motion profile. Leadshine also offers tuning software, ProTuner, which allows you to adjust those current-loop and position-loop parameters (see software manual).

## RS232 Communication Cable Connections

Note1: The RS232 communication port is not isolated. Please use an isolated power supply for the iSV-B23xxx when the PC's serial port is not isolated.

Note2: Do not plug or unplug the connector when power is on.

## Typical Connections

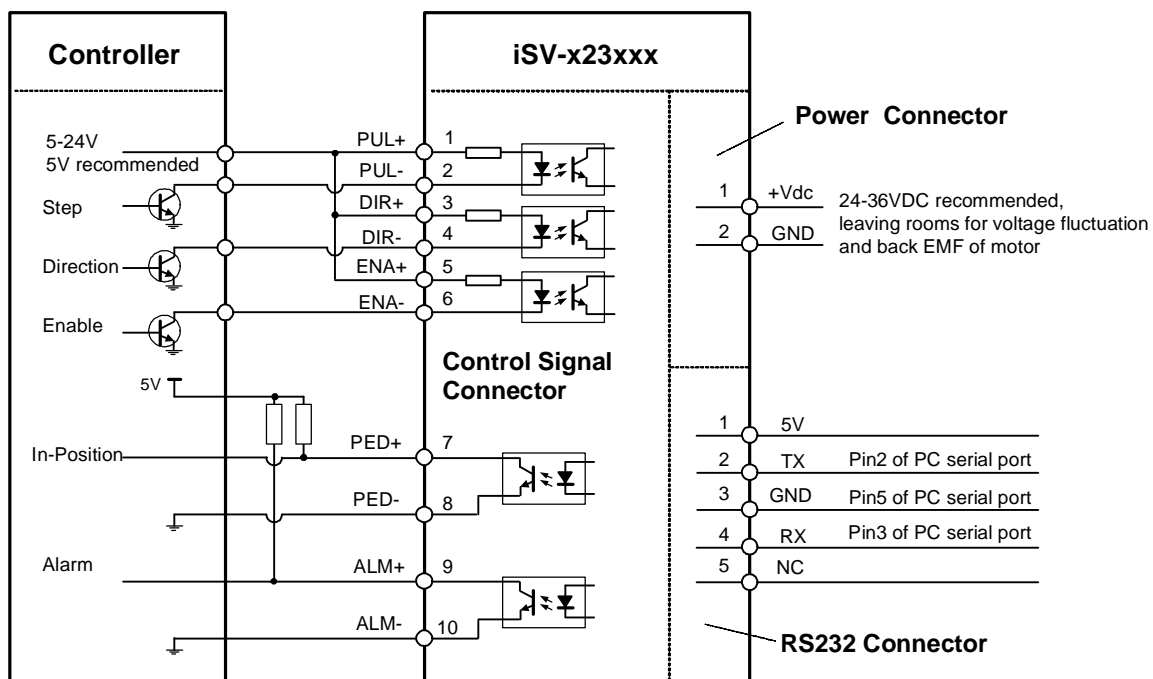

Connect iSV-B23xxx to controller of sinking output

### Typical Connections (Continued)

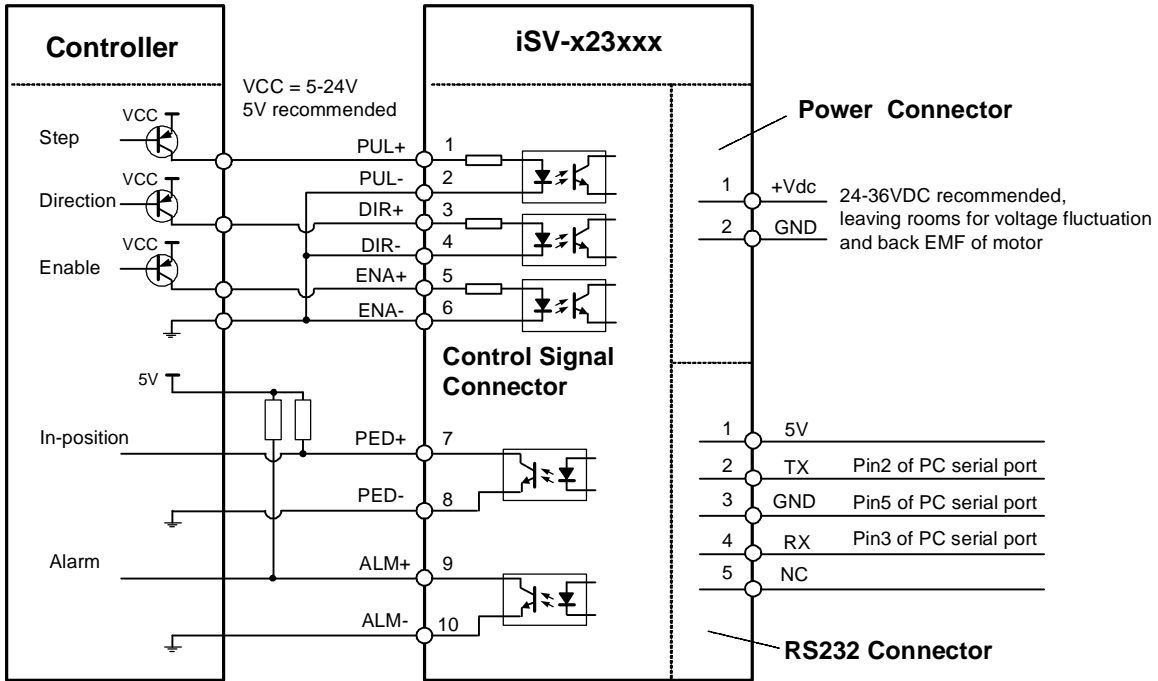

Connect iSV-B23xxx to controller of sourcing output

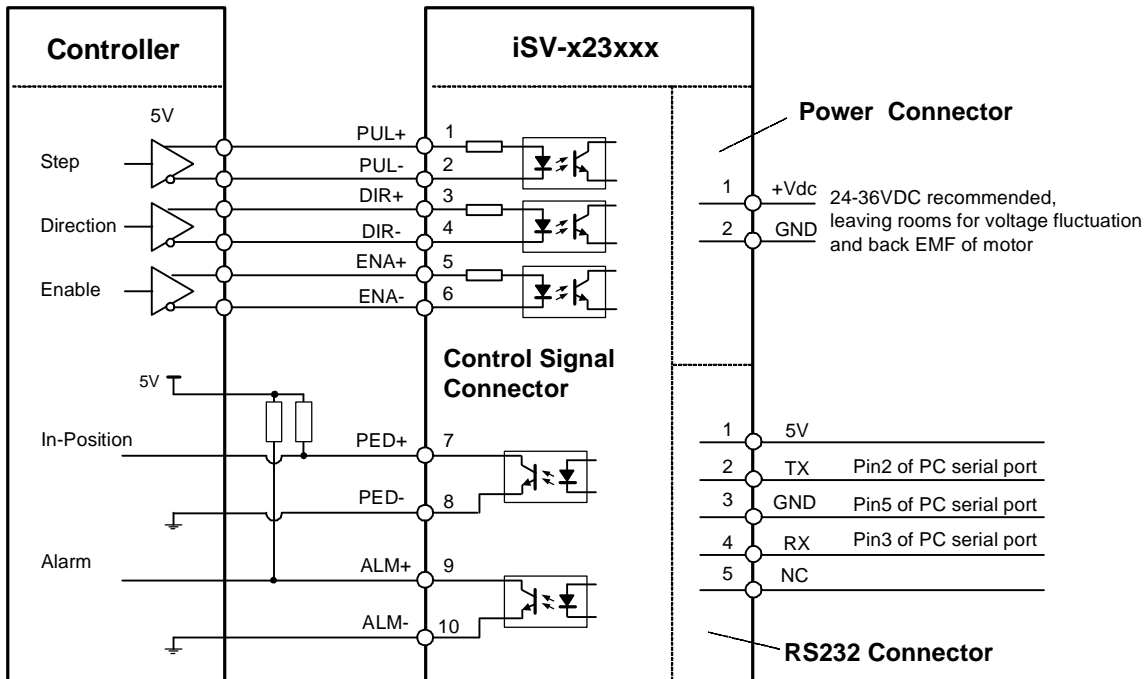

Connect iSV-B23xxx to controller of differential output